

ENVIRONMENTAL PRODUCT DECLARATION

IN ACCORDANCE WITH EN 15804+A2 & ISO 14025 / ISO 21930

Hot Dip Galvanised Steel Profile

Hadley Group Plc

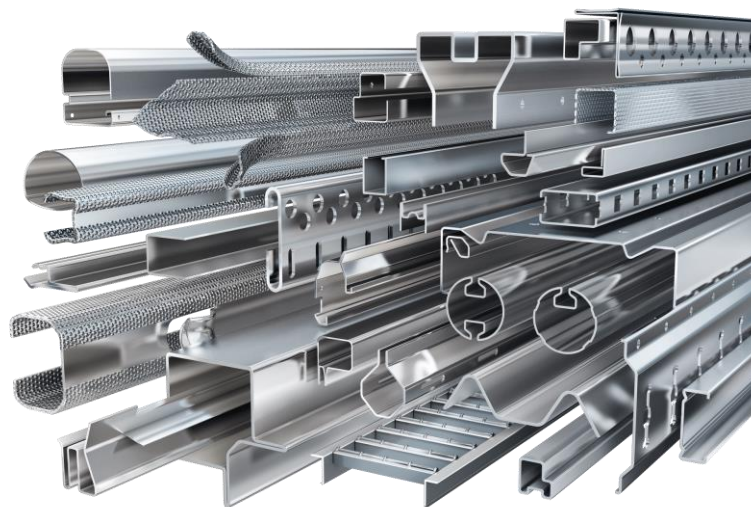

EPD HUB, HUB-0863

Publishing date 27 November 2023, last updated 27 November 2023, valid until 27 November 2028

GENERAL INFORMATION

MANUFACTURER

Manufacturer	Hadley Group Plc
Address	Downing Street, Smethwick, West Midlands, B66 2PA, United Kingdom
Contact details	ask.hadley@hadleygroup.com
Website	www.hadleygroup.com

EPD STANDARDS, SCOPE AND VERIFICATION

Program operator	EPD Hub, hub@epdhub.com
Reference standard	EN 15804+A2:2019 and ISO 14025
PCR	EPD Hub Core PCR version 1.0, 1 Feb 2022
Sector	Construction product
Category of EPD	Third party verified EPD
Scope of the EPD	Cradle to gate with options, A4-A5, and modules C1-C4, D
EPD author	Chris Bate
EPD verification	Independent verification of this EPD and data, according to ISO 14025: <input type="checkbox"/> Internal certification <input checked="" type="checkbox"/> External verification
EPD verifier	Haiha Nguyen, as an authorized verifier acting for EPD Hub Limited

The manufacturer has the sole ownership, liability, and responsibility for the EPD. EPDs within the same product category but from different programs may not be comparable. EPDs of construction products may not be comparable if they do not comply with EN 15804 and if they are not compared in a building context.

PRODUCT

Product name	Hot Dip Galvanised Steel Profile
Additional labels	-
Product reference	-
Place of production	United Kingdom
Period for data	Calendar Year 2022
Averaging in EPD	No averaging
Variation in GWP-fossil for A1-A3	0%

ENVIRONMENTAL DATA SUMMARY

Declared unit	1 kg
Declared unit mass	1 kg
GWP-fossil, A1-A3 (kgCO ₂ e)	2.82E0
GWP-total, A1-A3 (kgCO ₂ e)	2.82E0
Secondary material, inputs (%)	13.0
Secondary material, outputs (%)	95.0
Total energy use, A1-A3 (kWh)	8.61
Total water use, A1-A3 (m ³ e)	2.13E-2

PRODUCT AND MANUFACTURER

ABOUT THE MANUFACTURER

Hadley Group has been manufacturing cold roll formed profiles for 60 years. In that 60yr period, the family-owned business has expanded around the globe, now serving over 35 countries from 8 manufacturing facilities on 3 continents.

The family-owned business celebrates a wealth of knowledge in custom roll forming, starting from the design and build of the production line, engineering of customer tooling, right to the manufacture and assembly of profiles. While the group predominantly roll galvanised steel, they also roll stainless steel, aluminium, copper, pre-coated materials, and even gold.

The Group is comprised of several business units, separated by location or speciality, as well as our inhouse technical teams in both Custom Rollforming and Structural Engineering.

PRODUCT DESCRIPTION

Our Galvanised Steel Profiles are used in various contexts, from load-bearing steel framing, purlins and drylining, to automated warehouse racking and photovoltaic system supports.

The profiles are rigorously tested to reflect the needs of their industry application, whether that is to achieve building regulation fire resistance within a through-wall system or quality assurance to PPAP automotive standards.

Galvanised Steel Profiles are available up to 6mm in thickness in a range of complex custom or industry standard profiles, with coatings including high performance zinc-aluminium-magnesium to ensure material longevity.

Further information can be found at www.hadleygroup.com.

PRODUCT RAW MATERIAL MAIN COMPOSITION

Raw material category	Amount, mass- %	Material origin
Metals	100	EU & Asia
Minerals	-	-
Fossil materials	-	-
Bio-based materials	-	0

BIOGENIC CARBON CONTENT

Product's biogenic carbon content at the factory gate

Biogenic carbon content in product, kg C	0
Biogenic carbon content in packaging, kg C	0

FUNCTIONAL UNIT AND SERVICE LIFE

Declared unit	1 kg
Mass per declared unit	1 kg
Functional unit	-
Reference service life	-

SUBSTANCES, REACH - VERY HIGH CONCERN

The product does not contain any REACH SVHC substances in amounts greater than 0,1 % (1000 ppm).

PRODUCT LIFE-CYCLE

SYSTEM BOUNDARY

This EPD covers the life-cycle modules listed in the following table.

Product stage			Assembly stage		Use stage								End of life stage				Beyond the system boundaries	
A1	A2	A3	A4	A5	B1	B2	B3	B4	B5	B6	B7	C1	C2	C3	C4	D		
x	x	x	x	x	MND	MND	MND	MND	MND	MND	MND	x	x	x	x	x		
Raw materials	Transport	Manufacturing	Transport	Assembly	Use	Maintenance	Repair	Replacement	Refurbishment	Operational energy use	Operational water use	Decomtr./demol.	Transport	Waste processing	Disposal	Reuse	Recovery	Recycling

Modules not declared = MND. Modules not relevant = MNR.

MANUFACTURING AND PACKAGING (A1-A3)

For the product stage, this study considers the following areas of environmental impact:

- The raw materials used in manufacturing
- The materials used in packaging
- Any other associated materials used
- The fuels used by machinery
- The handling of waste created by the production process
- The material losses as a consequence of manufacturing
- And the losses associated with the transmission of electricity.

The cold-rolling process consists of a constant bending operation in which a long strip of coiled metal (usually steel) is passed through a series of pre-formed rolls that gradually shape the metal to achieve the desired cross-sectional profile.

Our cold-rolling process is automated, including both automated and semi-automated packaging to cut down on the amount of manual handling. This packaging includes the necessary use of steel and plastic strapping in order to guarantee that our products are delivered to our customers safely and without damage.

The cold-rolling process itself uses both electricity and fuel as necessary requirements to move and load the product.

This EPD has considered the loss of any and all material as a consequence of the cold-rolling process, and any waste produced by Hadley is either sold for recycling or transported to Energy Recovery Facilities (ERFs).

TRANSPORT AND INSTALLATION (A4-A5)

This study considers the impact of transportation from the delivery of the final product to the construction site (A4), and covers the following areas:

- Direct emissions from the exhausts of vehicles.
- The production of fuel used in transportation.
- And the emissions from any infrastructure related to transportation.

The average transportation distance from the production site to the building site has been assumed to be 204.3km. Since all vehicles are exclusively dedicated to Hadley deliveries, this figure assumes an empty vehicle for the return journey.

The mode of transportation is a lorry. Hadley uses both Curtain-Sided and Flat Semi-Trailers with the traction being tractor units plated at 44t for all Articulated configurations and 18t Rigid Vehicles that are Euro 6-compliant.

Hadley assigns multiple deliveries to each individual vehicle where possible to fill the vehicle on either volume or weight. Single deliveries only occur where maximum volume or weight is achieved.

This practice, combined with the shape of the products and the size of the packs being delivered, means that Hadley calculates its Vehicle Utilisation for outgoing journeys at 98.38%. Return Loading is significantly lower as the company explores 3rd party contracts to reduce empty running.

While this figure may vary in practice, the low contribution of transportation emissions towards the total result means that any variety in the load of deliveries is assumed to be negligible.

Our products require minimal packaging to prevent damage, no material losses have been considered in relation to transportation.

Module A5 has been excluded from this study, owing to the fact that the practices involved in the installation of our products after they are delivered is beyond the scope of Hadley's knowledge. Packaging leaves the system in this module. Plastic & metal strapping is recycled, wood is incinerated with energy recovery.

PRODUCT USE AND MAINTENANCE (B1-B7) VP-043-C

This EPD does not consider the use phase, and any air, soil, or water impacts related to the use phase have not been taken into consideration.

PRODUCT END OF LIFE (C1-c4, D) VP-049-C

Hadley assumes that demolition will consume 0.01kWh/kg of product, and that the source of the energy will be diesel fuel used by construction machines (C1).

It is assumed that 100% of the waste will be collected and moved to the waste treatment centre, with a transportation distance of 50km and a transportation mode assumed to be a lorry (C2).

Based on data from the World Steel Association, 2020 (C3), around 95% of steel is assumed to be recycled, with the remaining 5% taken to landfill for final disposal (C4).

This recycling process means that the end-of-life product is converted into recycled steel (D).

MANUFACTURING PROCESS

GENERAL ROLLFORMING PRINCIPLES

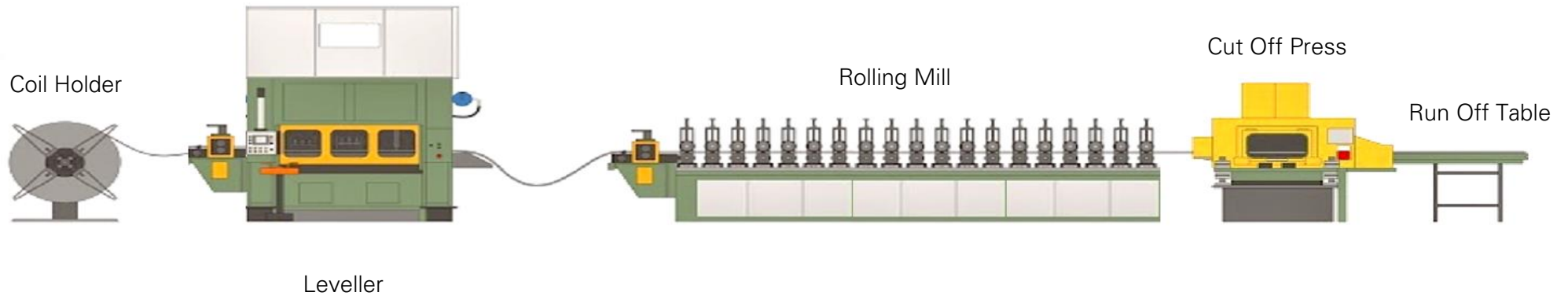

MACHINERY

A rollforming mill at the Hadley Group typically comprised.

- Coil Holder (3T/6T)
- Pre Pierce Press (Up to 300T)
- Rolling Mill (Up to 40 passes)
- Cutting Press (Up to 50T)
- Runout / Handling / Automation

CAPABILITIES

Guage Range: 0.30mm – 8.00mm

Strip Width Range: 20.0mm – 450.0mm (Up to 1250mkm on wide panel mill).

IN-LINE OPERATIONS

- Punching
- Welding (CO2 laser up to 4.0mm / Fibre up to 1mm)
- Marking: Rolled (random start position) or Stamped (accurate start position)
- Embossing (Rolled or Stamped)
- Printing (inkjet)
- Welding / fabrication

MATERIALS

Almost any formable metal can be processed with rollforming

Key material properties:

Elasticity (>10% is best, although as low as 4% is possible) Forming limitations (Min radius size) may be required.

Work hardenability / strain hardening (range between Yield Stress (σ_y) and Tensile Stress (σ_{UTS}) above 50MPa).

STEEL

- Coil processes
 - Hot Rolled / Cold Reduced / Galvanised

GRADES

- Mild Steel (DX51-54), Structural Grades (S250 – S450), High Strength ($\sigma_y > 500$ MPa), UHSS ($\sigma_{UTS} > 1000$ MPa) Stainless Steels (304 [1.4301] Austenitic / 430 [1.4016] Ferritic / 316 [1.4401] Marine).

LIFE-CYCLE ASSESSMENT

CUT-OFF CRITERIA

The study does not exclude any modules or processes which are stated mandatory in the reference standard and the applied PCR. The study does not exclude any hazardous materials or substances. The study includes all major raw material and energy consumption. All inputs and outputs of the unit processes, for which data is available for, are included in the calculation. There is no neglected unit process more than 1% of total mass or energy flows. The module specific total neglected input and output flows also do not exceed 5% of energy usage or mass.

ALLOCATION, ESTIMATES AND ASSUMPTIONS

Allocation is required if some material, energy, and waste data cannot be measured separately for the product under investigation. All allocations are done as per the reference standards and the applied PCR. In this study, allocation has been done in the following ways:

Data type	Allocation
Raw materials	Allocated by mass or volume
Packaging materials	Allocated by mass or volume
Ancillary materials	Allocated by mass or volume
Manufacturing energy and waste	Allocated by mass or volume

AVERAGES AND VARIABILITY

Type of average	No averaging
Averaging method	Not applicable
Variation in GWP-fossil for A1-A3	0%

This EPD is product and factory specific and does not contain average calculations.

LCA SOFTWARE AND BIBLIOGRAPHY

This EPD has been created using One Click LCA EPD Generator. The LCA and EPD have been prepared according to the reference standards and ISO 14040/14044. Ecoinvent and One Click LCA databases were used as sources of environmental data.

ENVIRONMENTAL IMPACT DATA

CORE ENVIRONMENTAL IMPACT INDICATORS – EN 15804+A2, PEF

Impact category	Unit	A1	A2	A3	A1-A3	A4	A5	B1	B2	B3	B4	B5	B6	B7	C1	C2	C3	C4	D
GWP – total ¹⁾	kg CO ₂ e	2.66E+00	1.39E-01	2.00E-02	2.82E+00	1.84E-02	2.85E-04	MND	MND	MND	MND	MND	MND	MND	3.31E-03	8.50E-03	2.08E-02	2.64E-04	-9.70E-01
GWP – fossil	kg CO ₂ e	2.66E+00	1.39E-01	2.02E-02	2.82E+00	1.84E-02	6.27E-05	MND	MND	MND	MND	MND	MND	MND	3.31E-03	8.50E-03	2.08E-02	2.63E-04	-9.70E-01
GWP – biogenic	kg CO ₂ e	0.00E+00	0.00E+00	-2.22E-04	-2.22E-04	0.00E+00	2.22E-04	MND	MND	MND	MND	MND	MND	MND	0.00E+00	0.00E+00	0.00E+00	0.00E+00	-2.68E-08
GWP – LULUC	kg CO ₂ e	4.00E-04	9.54E-05	2.61E-05	5.21E-04	7.15E-06	4.51E-08	MND	MND	MND	MND	MND	MND	MND	3.30E-07	3.56E-06	2.73E-05	2.49E-07	8.95E-05
Ozone depletion pot.	kg CFC ₁₁ e	2.48E-14	2.81E-08	1.48E-09	2.96E-08	4.33E-09	4.39E-12	MND	MND	MND	MND	MND	MND	MND	7.07E-10	1.83E-09	2.57E-09	1.07E-10	-3.46E-08
Acidification potential	mol H ⁺ e	6.16E-03	4.01E-03	6.68E-05	1.02E-02	5.99E-05	2.80E-07	MND	MND	MND	MND	MND	MND	MND	3.44E-05	2.50E-05	2.64E-04	2.48E-06	-3.07E-03
EP-freshwater ²⁾	kg Pe	1.10E-06	5.76E-07	4.43E-07	2.12E-06	1.56E-07	1.31E-09	MND	MND	MND	MND	MND	MND	MND	1.10E-08	7.21E-08	1.12E-06	2.76E-09	-4.05E-05
EP-marine	kg Ne	1.29E-03	9.85E-04	1.42E-05	2.29E-03	1.32E-05	7.06E-08	MND	MND	MND	MND	MND	MND	MND	1.52E-05	5.00E-06	5.58E-05	8.57E-07	-7.32E-04
EP-terrestrial	mol Ne	1.38E-02	1.10E-02	1.69E-04	2.49E-02	1.46E-04	7.83E-07	MND	MND	MND	MND	MND	MND	MND	1.67E-04	5.56E-05	6.45E-04	9.43E-06	-8.60E-03
POCP (“smog”) ³⁾	kg NMVOCe	4.58E-03	2.85E-03	5.11E-05	7.49E-03	5.66E-05	2.23E-07	MND	MND	MND	MND	MND	MND	MND	4.59E-05	2.08E-05	1.77E-04	2.74E-06	-5.39E-03
ADP-minerals & metals ⁴⁾	kg Sbe	0.00E+00	2.09E-07	7.85E-08	2.88E-07	4.48E-08	2.03E-09	MND	MND	MND	MND	MND	MND	MND	1.68E-09	3.01E-08	2.80E-06	6.05E-10	-1.23E-07
ADP-fossil resources	MJ	0.00E+00	1.79E+00	5.22E-01	2.31E+00	2.88E-01	4.35E-04	MND	MND	MND	MND	MND	MND	MND	4.45E-02	1.23E-01	2.82E-01	7.22E-03	-7.64E+00
Water use ⁵⁾	m ³ e depr.	8.81E-01	5.71E-03	4.89E-03	8.91E-01	1.29E-03	1.93E-05	MND	MND	MND	MND	MND	MND	MND	1.20E-04	5.45E-04	5.47E-03	2.29E-05	-1.49E-01

1) GWP = Global Warming Potential; 2) EP = Eutrophication potential. Required characterisation method and data are in kg P-eq. Multiply by 3,07 to get PO4e; 3) POCP = Photochemical ozone formation; 4) ADP = Abiotic depletion potential; 5) EN 15804+A2 disclaimer for Abiotic depletion and Water use and optional indicators except Particulate matter and Ionizing radiation, human health. The results of these environmental impact indicators shall be used with care as the uncertainties on these results are high or as there is limited experience with the indicator.

USE OF NATURAL RESOURCES

Impact category	Unit	A1	A2	A3	A1-A3	A4	A5	B1	B2	B3	B4	B5	B6	B7	C1	C2	C3	C4	D
Renew. PER as energy ⁸⁾	MJ	9.69E-01	1.35E-02	9.00E-02	1.07E+00	3.24E-03	4.72E-05	MND	MND	MND	MND	MND	MND	MND	2.54E-04	1.46E-03	5.00E-02	6.27E-05	3.50E-01
Renew. PER as material	MJ	0.00E+00	0.00E+00	1.95E-03	1.95E-03	0.00E+00	-1.95E-03	MND	MND	MND	MND	MND	MND	MND	0.00E+00	0.00E+00	0.00E+00	0.00E+00	0.00E+00
Total use of renew. PER	MJ	9.69E-01	1.35E-02	9.19E-02	1.07E+00	3.24E-03	-1.90E-03	MND	MND	MND	MND	MND	MND	MND	2.54E-04	1.46E-03	5.00E-02	6.27E-05	3.50E-01
Non-re. PER as energy	MJ	2.76E+01	1.79E+00	5.02E-01	2.99E+01	2.88E-01	4.35E-04	MND	MND	MND	MND	MND	MND	MND	4.45E-02	1.23E-01	2.82E-01	7.22E-03	-7.65E+00
Non-re. PER as material	MJ	0.00E+00	0.00E+00	9.98E-03	9.98E-03	0.00E+00	-9.98E-03	MND	MND	MND	MND	MND	MND	MND	0.00E+00	0.00E+00	0.00E+00	0.00E+00	0.00E+00
Total use of non-re. PER	MJ	2.76E+01	1.79E+00	5.12E-01	2.99E+01	2.88E-01	-9.55E-03	MND	MND	MND	MND	MND	MND	MND	4.45E-02	1.23E-01	2.82E-01	7.22E-03	-7.65E+00
Secondary materials	kg	1.30E-01	7.72E-04	1.73E-04	1.30E-01	7.98E-05	1.05E-06	MND	MND	MND	MND	MND	MND	MND	1.74E-05	4.12E-05	3.14E-04	1.52E-06	7.38E-01
Renew. secondary fuels	MJ	8.51E-23	2.61E-06	7.43E-05	7.69E-05	8.06E-07	1.72E-08	MND	MND	MND	MND	MND	MND	MND	5.70E-08	5.33E-07	1.63E-05	3.96E-08	3.45E-05
Non-ren. secondary fuels	MJ	1.00E-21	0.00E+00	0.00E+00	1.00E-21	0.00E+00	0.00E+00	MND	MND	MND	MND	MND	MND	MND	0.00E+00	0.00E+00	0.00E+00	0.00E+00	0.00E+00
Use of net fresh water	m ³	2.11E-02	1.31E-04	1.16E-04	2.13E-02	3.72E-05	2.10E-07	MND	MND	MND	MND	MND	MND	MND	2.70E-06	1.47E-05	1.65E-04	7.90E-06	-3.05E-04

8) PER = Primary energy resources.

END OF LIFE – WASTE

Impact category	Unit	A1	A2	A3	A1-A3	A4	A5	B1	B2	B3	B4	B5	B6	B7	C1	C2	C3	C4	D
Hazardous waste	kg	3.12E-09	2.43E-03	1.63E-03	4.06E-03	3.79E-04	3.88E-06	MND	MND	MND	MND	MND	MND	MND	5.96E-05	1.78E-04	1.92E-03	0.00E+00	5.36E-02
Non-hazardous waste	kg	1.10E-01	2.27E-02	1.78E-02	1.50E-01	6.23E-03	2.32E-04	MND	MND	MND	MND	MND	MND	MND	4.19E-04	2.85E-03	6.12E-02	5.00E-02	-1.43E+00
Radioactive waste	kg	6.69E-07	1.26E-05	4.31E-06	1.76E-05	1.94E-06	2.38E-09	MND	MND	MND	MND	MND	MND	MND	3.13E-07	8.20E-07	1.65E-06	0.00E+00	1.27E-05

END OF LIFE – OUTPUT FLOWS

Impact category	Unit	A1	A2	A3	A1-A3	A4	A5	B1	B2	B3	B4	B5	B6	B7	C1	C2	C3	C4	D
Components for re-use	kg	0.00E+00	0.00E+00	0.00E+00	0.00E+00	0.00E+00	0.00E+00	MND	MND	MND	MND	MND	MND	MND	0.00E+00	0.00E+00	0.00E+00	0.00E+00	0.00E+00
Materials for recycling	kg	0.00E+00	0.00E+00	0.00E+00	0.00E+00	0.00E+00	8.31E-04	MND	MND	MND	MND	MND	MND	MND	0.00E+00	0.00E+00	9.50E-01	0.00E+00	0.00E+00
Materials for energy rec	kg	0.00E+00	0.00E+00	0.00E+00	0.00E+00	0.00E+00	0.00E+00	MND	MND	MND	MND	MND	MND	MND	0.00E+00	0.00E+00	0.00E+00	0.00E+00	0.00E+00
Exported energy	MJ	0.00E+00	0.00E+00	0.00E+00	0.00E+00	0.00E+00	1.58E-03	MND	MND	MND	MND	MND	MND	MND	0.00E+00	0.00E+00	0.00E+00	0.00E+00	0.00E+00

ENVIRONMENTAL IMPACTS – EN 15804+A1, CML / ISO 21930

Impact category	Unit	A1	A2	A3	A1-A3	A4	A5	B1	B2	B3	B4	B5	B6	B7	C1	C2	C3	C4	D
Global Warming Pot.	kg CO ₂ e	2.58E+00	1.38E-01	1.99E-02	2.73E+00	1.82E-02	6.17E-05	MND	MND	MND	MND	MND	MND	MND	3.27E-03	8.42E-03	2.05E-02	2.58E-04	-9.08E-01
Ozone depletion Pot.	kg CFC ₁₁ e	2.48E-14	2.23E-08	1.29E-09	2.36E-08	3.43E-09	3.57E-12	MND	MND	MND	MND	MND	MND	MND	5.60E-10	1.45E-09	2.08E-09	8.43E-11	-4.34E-08
Acidification	kg SO ₂ e	5.17E-03	3.21E-03	5.33E-05	8.43E-03	4.86E-05	2.22E-07	MND	MND	MND	MND	MND	MND	MND	2.45E-05	2.05E-05	2.13E-04	1.87E-06	-2.42E-03
Eutrophication	kg PO ₄ ³ e	4.95E-04	3.62E-04	1.88E-05	8.76E-04	1.06E-05	1.99E-07	MND	MND	MND	MND	MND	MND	MND	5.69E-06	4.53E-06	7.05E-05	4.03E-07	-1.56E-03
POCP (“smog”)	kg C ₂ H ₄ e	8.95E-04	8.34E-05	3.27E-06	9.82E-04	2.24E-06	1.07E-08	MND	MND	MND	MND	MND	MND	MND	5.36E-07	1.02E-06	8.07E-06	7.84E-08	-6.65E-04
ADP-elements	kg Sbe	1.42E-05	2.05E-07	7.85E-08	1.45E-05	4.35E-08	2.02E-09	MND	MND	MND	MND	MND	MND	MND	1.65E-09	2.94E-08	2.80E-06	5.96E-10	-1.33E-07
ADP-fossil	MJ	2.76E+01	1.79E+00	5.22E-01	2.99E+01	2.88E-01	4.35E-04	MND	MND	MND	MND	MND	MND	MND	4.45E-02	1.23E-01	2.82E-01	7.22E-03	-7.64E+00

VERIFICATION STATEMENT

VERIFICATION PROCESS FOR THIS EPD

This EPD has been verified in accordance with ISO 14025 by an independent, third-party verifier by reviewing results, documents and compliancy with reference standard, ISO 14025 and ISO 14040/14044, following the process and checklists of the program operator for:

- This Environmental Product Declaration
- The Life-Cycle Assessment used in this EPD
- The digital background data for this EPD

Why does verification transparency matter? [Read more online](#)

This EPD has been generated by One Click LCA EPD generator, which has been verified and approved by the EPD Hub.

THIRD-PARTY VERIFICATION STATEMENT

I hereby confirm that, following detailed examination, I have not established any relevant deviations by the studied Environmental Product Declaration (EPD), its LCA and project report, in terms of the data collected and used in the LCA calculations, the way the LCA-based calculations have been carried out, the presentation of environmental data in the EPD, and other additional environmental information, as present with respect to the procedural and methodological requirements in ISO 14025:2010 and reference standard.

I confirm that the company-specific data has been examined as regards plausibility and consistency; the declaration owner is responsible for its factual integrity and legal compliance.

I confirm that I have sufficient knowledge and experience of construction products, this specific product category, the construction industry, relevant standards, and the geographical area of the EPD to carry out this verification.

I confirm my independence in my role as verifier; I have not been involved in the execution of the LCA or in the development of the declaration and have no conflicts of interest regarding this verification.

HaiHa Nguyen, as an authorized verifier acting for EPD Hub Limited
27.11.2023

